

COMPOSITE SQUARE FLANGE JACK RECEPTACLE

R187.406.000

PANEL SEAL - FRONT MOUNTING M3 SCREW

S : 7/16 COMPOSITE

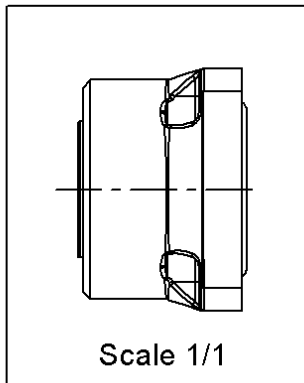
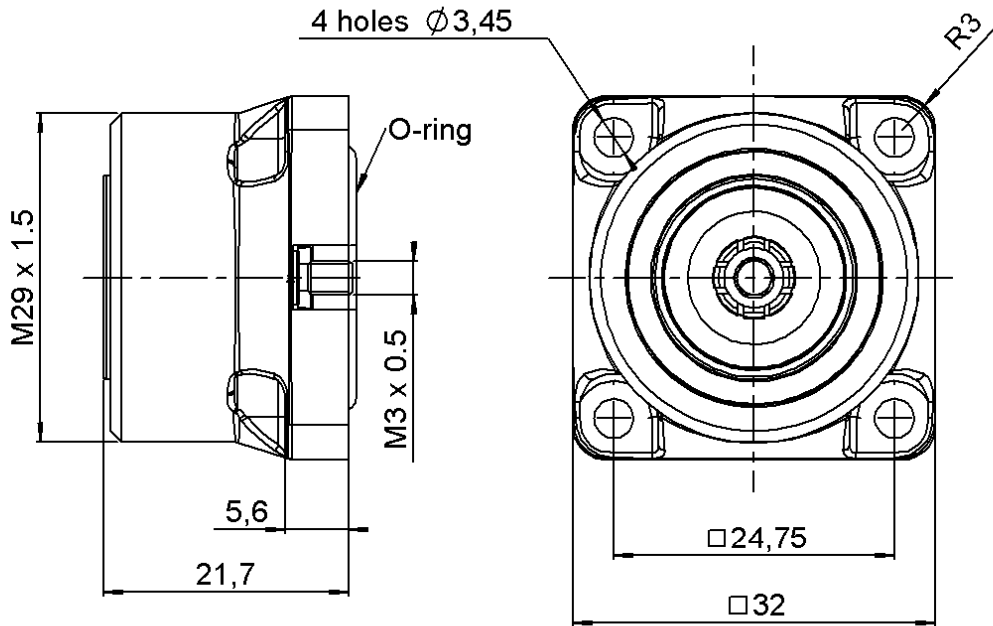

PANEL CUT OUT

	mm	
	Maxi	mini
A	16.2	16
B	3.7	3.6
C	24.8	24.7

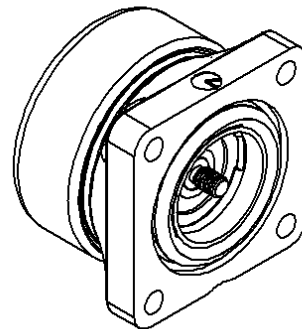

All dimensions are in mm.

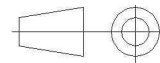

COMPONENTS	MATERIALS	PLATING (µm)
BODY	COMPOSITE MATERIAL - BLACK	-
CENTER CONTACT	BRONZE	SILVER 5 OVER COPPER 0.5
OUTER CONTACT	BRASS	SILVER 3 OVER BBR 0.5
INSULATOR	PTFE	-
GASKET	SILICONE RUBBER	-
OTHERS PARTS	-	-
-	-	-
-	-	-

Issue : 0834 B

In the effort to improve our products, we reserve the right to make changes judged to be necessary.



COMPOSITE SQUARE FLANGE JACK RECEPTACLE

R187.406.000

PANEL SEAL - FRONT MOUNTING M3 SCREW

S : 7/16 COMPOSITE

PACKAGING

SPECIFICATION

Standard	Unit	Other
20	'W' option	Contact us

ELECTRICAL CHARACTERISTICS

ENVIRONMENTAL

Impedance	50	Ω
Frequency	0-7.5	GHz
VSWR	*1.06 + 0,0000	x F(GHz) Maxi
Insertion loss	0.05	\sqrt{F} (GHz) dB Maxi
RF leakage	- (NA	- F(GHz)) dB Maxi
Voltage rating	1400	Veff Maxi
Dielectric withstanding voltage	2700	Veff mini
Insulation resistance	10000	M Ω mini

Operating temperature	-40/+85	$^{\circ}$ C
Hermetic seal		Atm.cm3/s
Panel leakage	IP67	

OTHER CHARACTERISTICS

Assembly instruction

Others :

*VSWR : 1.06 between DC to 3GHz

*VSWR : 1.10 between 3 to 7.5GHz

PIM3:-125dBm under 2 carriers of +43dBm

Flammability rating : UL94-V0

UV resistance : IEC68-2-5 (1000h@1250W/m²)

MECHANICAL CHARACTERISTICS

Center contact retention		
Axial force – Mating end	200	N mini
Axial force – Opposite end	100	N mini
Torque	50	N.cm mini

Recommended torque

Mating	N.cm
Panel nut	N.cm

Mating life	500	Cycles mini
Weight	24,6200	g

Issue : 0834 B

In the effort to improve our products, we reserve the right to make changes judged to be necessary.

